



# Mini-Krane

8,70 Meter

## TECHNISCHE INFORMATIONEN

Modellbezeichnung	MC-285 CRM-E
Max. Hakenhöhe	8,70 m
Max. Reichweite	8,20 m
Tragfähigkeit	2.820 kg x 1,4 m
Schwenkbereich	360° endlos
Seilgeschwindigkeit	8,0 m / Min.
Steigfähigkeit	20°
Laufwerksystem	Hydrostatisch, stufenlose Geschwindigkeit
Antrieb	Diesel oder 380 V vom Netz
Gewicht	1.950 kg
Ketten:	Non marking Gummikette weiße Gummiketten

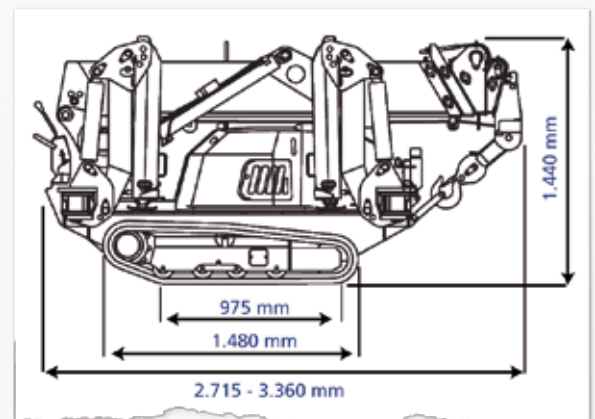
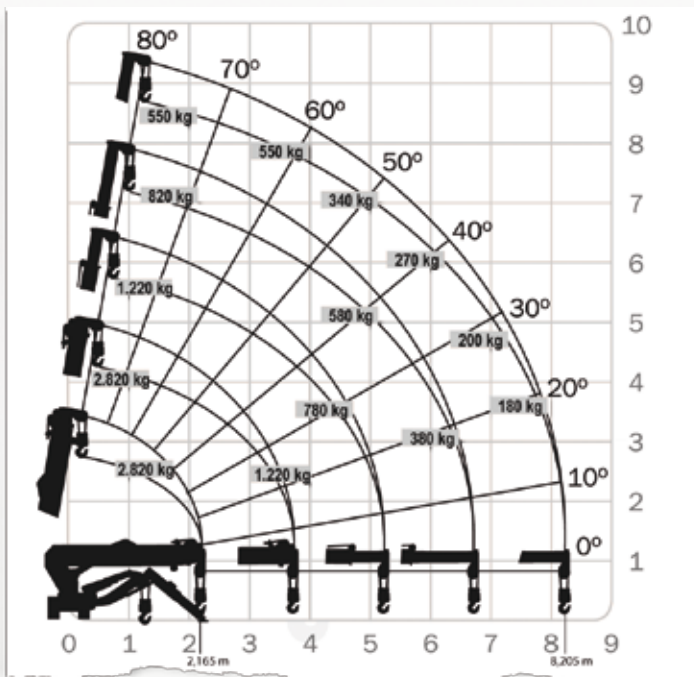

# Mini-Krane

8,70 Meter

